

Nuovo Esperimento	Gruppo
BENHUR	5

Struttura
L.N.L.

Ricercatore
responsabile locale: PALMIERI Vincenzo

Rappresentante Nazionale: V. PALMIERI

Struttura di appartenenza: LNL

Posizione nell'I.N.F.N.: Primo Ricercatore

PROGRAMMA DI RICERCA

A) INFORMAZIONI GENERALI

Linea di ricerca	CARATTERIZZAZIONE TRAMITE MAGNETOMETRIA A FLUX GATE DEL PROCESSO DI ATTACCO CHIMICO ED ELETTROCHIMICO IN CAVITA' RISONANTE
Laboratorio ove si raccolgono i dati	L.N.L., INFN Unita' di Napoli
Acceleratore usato	
Fascio (sigla e caratteristiche)	
Processo fisico studiato	Letture del segnale magnetico associato all'etching chimico ed al processo di elettropulitura costruzione dispositivo per misurare l'RRR locale del Niobio di una cavita'.
Apparato strumentale utilizzato	Cavita' acceleratrici superconduttive, chimico ed elettrochimico. Magnetometria a squid, fluxgate ed hall probes.
Sezioni partecipanti all'esperimento	LNL
Istituzioni esterne all'Ente partecipanti	INFN (Unita' di Napoli nell'ambito progetto sud) Industria:ditta TLC
Durata esperimento	2 Anni

B) SCALA DEI TEMPI: piano di svolgimento

PERIODO	ATTIVITA' PREVISTA
2001	Costruzione impianto chimico per il Niobio Costruzione array di magnetometri. Studio del processo chimico ed elettrochimico del Niobio con l'ausilio della lettura magnetometrica
2002	Studio delle problematiche di monitoraggio Eddy currents in geometrie a simmetria di rivoluzione misura dell'RRR di cavita' in Niobio. Tomografia misura del desorbimento d'idrogeno con annealing in cryostato.

Mod. EN. 1

(a cura del rappresentante nazionale)

Nuovo Esperimento	Gruppo
BENHUR	5

Struttura
L.N.L.

PREVENTIVO LOCALE DI SPESA PER L'ANNO
2001
In ML

VOCI DI SPESA	DESCRIZIONE DELLA SPESA	IMPORTI		A cura della Comm.ne Scientifica Nazionale
		Parziali	Totale Compet.	
Viaggi e missioni	Interno Contatti ditte chimica, trasferte NA-LNL	9	9	
	Estero Contatti CERN, Jlab. Conferenza	15	15	
Materiale Consumo	Acidi Smaltimento reflui Materiali inerti (Teflon, PVDF, Vetriere)	6 10 4	20	
Trasp.e facch.				
Spese Calcolo	Consorzio			
	Ore CPU			
	Spazio Disco			
	Cassette			
	Altro			
Affitti e manutenz. apparecchiati.				
Materiale Inventariabile				
Costruzione Apparati	Pompe, vasche, ph-metri, tubazioni etc per costruzione impianto chimico x Niobio	80	80	
Totale			124	
Note:				

- 1) Contributo richiesto Div. Acceleratori per impiantistica laboratorio =100ML
- 2) Finanziamento industria privata=75ML
- 3) Disponibilita' utilizzo strutture INFN minore/uguale 300ML

Nuovo Esperimento	Gruppo
BENHUR	5

Struttura
L.N.L.

PREVISIONE DI SPESA: PIANO FINANZIARIO LOCALE

PER GLI ANNI DELLA DURATA DEL PROGETTO

In ML

ANNI FINANZIARI	Miss. interno	Miss. estero	Mater. di cons.	Trasp.e Facch.	Spese Calcolo	Affitti e manut. appar.	Mat. inventar.	Costruz. apparati	TOTALE Competenza
2001	9	15	20					80	124
2002	9	15	20					57	101
TOTALI	18	30	40					137	225

Note:

Osservazioni del Direttore della Struttura in merito alla disponibilità di personale e di attrezzature:

Mod. EN. 3

(a cura del responsabile locale)

Nuovo Esperimento	Gruppo
BENHUR	5

Struttura
L.N.L.

PREVISIONE DI SPESA

Piano finanziario globale di spesa

In ML

ANNI FINANZIARI	Miss. interno	Miss. estero	Materiale di cons.	Trasp.e Facch.	Spese Calcolo	Affitti e manut. appar.	Mat. inventar.	Costruz. apparati	TOTALE Competenza
2001	9	15	20					80	124
2002	9	15	20					57	101
TOTALI	18	30	40					137	225

Note:

ISTITUTO NAZIONALE DI FISICA NUCLEARE

Preventivo per l'anno **2001**

Nuovo Esperimento	Gruppo
BENHUR	5

Struttura
L.N.L.

PROPOSTA DI NUOVO ESPERIMENTO

All'esperimento BENHUR partecipano.:
Due Borsisti della TLC (vedi allegato)
Personale dell'INFM (vedi lettera)

Codice	Esperimento	Gruppo
	BENHUR	5

Struttura
L.N.L.

COMPOSIZIONE DEL GRUPPO DI RICERCA (cont.)

LAUREANDI Cognome e Nome	Associazione		Titolo della Tesi
	SI	NO	
Relatore	<input type="radio"/> SI	<input type="radio"/> NO	
Relatore	<input type="radio"/> SI	<input type="radio"/> NO	
Relatore	<input type="radio"/> SI	<input type="radio"/> NO	
Relatore	<input type="radio"/> SI	<input type="radio"/> NO	
Relatore	<input type="radio"/> SI	<input type="radio"/> NO	
Relatore	<input type="radio"/> SI	<input type="radio"/> NO	
Relatore	<input type="radio"/> SI	<input type="radio"/> NO	
Relatore	<input type="radio"/> SI	<input type="radio"/> NO	

	Denominazione	mesi-uomo	SERVIZI TECNICI Annotazioni
1	O.Meccanica	3	
			Si richiede l'assistenza del sig. R. Preciso

INTERAZIONI CON LE INDUSTRIE (COMMESSE HIGH TECH)

DENOMINAZIONE	DESCRIZIONE PRODOTTO O COMMESSA
Ditta TLC	Finanziamento borse di studio per ingegnerizzare e commercializzare dispositivo finale.

Codice	Esperimento	Gruppo
	BENHUR	5

Struttura
L.N.L.

REFEREES DEL PROGETTO	
Cognome e Nome	Argomento
	Chimica-Elettrochimica
	Superconduttività- cavità

MILESTONES PROPOSTE PER IL 2001	
Data completamento	Descrizione
Giugno 2000	Studio dinamica e elettrochimica Nb su campioni e del Cu su cavità.
Settembre 2000	Fine costruzione impianto Niobio.
Dicembre 2000	Prove dell'array su cavità Nb
Giugno 2001	Misure RRR su campioni
Dicembre 2001	Misura RRR su cavità

COMPETITIVITA' INTERNAZIONALE
<p>Un tale strumento può essere utilizzato sia per misurare l'RRR del Niobio in cavità, sia per monitorare l'attacco chimico e elettrochimico. Questo dispositivo non esiste al momento, ma sarebbe fortemente auspicato della comunità internazionale. In più esiste una ditta interessata a commercializzarlo.</p>

LEADERSHIPS NEL PROGETTO	
Cognome e Nome	Funzioni svolte
PALMIERI Vincenzo	Chimica ed elettrochimica cavità
VALENTINO M. (INFM)	Magnetometria

ESPERIMENTO BENHUR

Il problema dell' etching chimico nelle cavita' superconduttrici di Niobio e' un problema complesso. La chimica del Niobio ed ancor meno l'elettrochimica sono processi poco studiati a causa delle limitate applicazioni sia commerciali che militari.

D'altro canto al momento la comunita' internazionale delle cavita' superconduttrici al momento e' globalmente orientata ad ottimizzare il processo di l'elettropulitura del niobio, perche' questa e' l'unica tecnica che permette di superare i 40 MV/m di campo accelerante in cavita'.

Il problema del' elettropulitura di una cavita' viene d'altronde affrontato sulla base di considerazioni empiriche. La forma del catodo e' ben lungi dall' essere ottimizzata per il profilo delle cavita' ed i rate di rimozione dalle pareti della cavita' sono incontrollati. Per fare un esempio, se il catodo e' un semplice tubo come quello adottato a KEK, per rimuovere 100 micron all' equatore bisogna rimuovere 300 micron all' iride. Per cavita' disuniformi in spessore, questo poui pou' essere addirittura un limita al numero di etchings applicabile sulla stessa cavita'.

Inoltre il segnale elettrico preso ai capi dell' anodo e del catodo, anche se si usa un'elettrodo di riferimento e' un segnale integrale, che media su tutta la cavita' e non tiene conto delle differenze di etching nei vari punti del risonatore.

Presso l'unita INFM di Napoli e' presnte un gruppo il quale si occupa di diagnostica non distruttiva di materiali tramite magnetometria SQUID e a Fluxgate. Inducendo delle eddy currents superficiali su pannelli, i magnetometri possono leggere anomalie nel percorsso delle correnti e quindi diagnosticare la presenza di microcricche.

L'idea alla base dell' esperimento BENHUR e' quella di accoppiare la magnetometria al processo chimico ed elettrochimico. Per esempio nel caso dell' attacco chimico del niobio in acido fluoridrico, nitrico e fosforico, quello che succede e' che il nitrico ossida il Niobio; il Fluoridrico riduce l'ossido in un sale solubile in acqua; il fosforico fa da moderatore alla reazione. Durante ognuno dei processi di ossidazione e di riduzione c'e' un trasferimento di carica , quindi una corrente quindi un campo magnetico. Probabilmente questo campo magnetico e' estremamente piccolo, ma in verita' nell' attacco acido in una cavita' vengono asportati spessori di micron al minuto e questo fa si' che i campi non devono essere proprio piccolissimi. D'altronde con la magnetometria SQUID si apprezzano campi di femtotesla.

E' stato fatto un esperimento per verificare la consistenza di questa idea ed e' stato presentato un articolo (allegato alla presente) al workshop sulla Superconduttivita' RF di Santa fe'. I campi sono addirittura delle centinaia di nanotesla e si possono monitorare con un semplice flux gate che diversamente dallo SQUID non ha bisogno di temperature criogeniche. E' stato misurato su campioni il rate di etching in funzione del fosforico e si vede che c'e' proporzionalita' con il segnale magnetico.

Il dispositivo ideato e' di nuova concezione e non risulta che alcuno abbia avuto l'idea di applicare la magnetometria per studiare il processo chimico o elettrochimico, ne' di cavita' ne' di altri oggetti.

Il poster presentato a Santa Fe' ha suscitato notevole interesse presso i laboratori coinvolti nell' elettrochimica delle cavita' (allegata lettera CERN). Il motivo e' che un'array di magnetometri siffatto pou' leggere dall' esterno della cavita' il rate di etching locale. Questo permette di capire immediatamente qual'e' la forma piu' opportuna di catodo per ottimizzare l'attacco chimico.

Ma non e' tutto: Bisogna sapere che l'idrogeno ha un interazione spin spin con l'idrogeno anomalmente alta. Infatti un modo per poter misurare l'assorbimento d'idrogeno nel niobio e' quello di misurarne il paramagnetismo. L'idrogeno e' importante per le cavita' a causa del Q-disease, cioe' dell' abbassamento del fattore di merito dovuto al contenuto d'idrogeno presente sulla superficie del superconduttore, lo si cura in modo empirico facendo annealings del niobio ad una temperatura che varia da laboratorio a laboratorio e per un tempo che parimenti varia da posto a posto.

Si intenderebbe quindi proporre lo studio del desorbimento dell' idrogeno dal niobio in funzione delle temperature e del tempo di annealing, guardando l'integrale di spettro letto dal magnetometro.

L'ultima applicazione proposta e' la valutazione del Residual Resistivity Ratio (RRR). L'RRR lo si misura da una lastra tagliandone un filo sottile, ma nessuno sa' quanto e' l'RRR di una cavita' in Niobio dopo la formatura, a meno che non la si tagli a fette. Inducendo impulsi sulla superficie della cavita' e leggendo il segnale magnetico, si puo' vedere la resistivita' locale del materiale.

L'esperimento si prevede in collaborazione con l'unita' INFM di Napoli, unendo le competenze INFN di cavita' ed elettrochimica con quelle INFM di magnetometria. Si allega alla presente lettera al presidente di Gruppo V da parte del Direttore Generale INFM che stabilisce la disponibilita' INFM a metter a disposizione "risorse umane e finanziarie" gia' stanziati nell' ambito del progetto SUD e con questo strumentazione per un valore non inferiore a 300 Milioni.

Esistono inoltre due ditte, la Promete e la TLC rispettivamente interessate una alla ingegnerizzazione del prototipo che verrebbe studiato nell' ambito dell' esperimento, l'altra alla commercializzazione del dispositivo gia' ingegnerizzato.

Si allega inoltre lettera del finanziamento gia' ottenuto dalla TLC atto a costituire capitale di finanziamento di borse di studio da usufruire per il progetto.

Allegati:

- Articolo: A new tool to monitor Niobium chemistry
- Lettera CERN di richiesta quotazione del dispositivo che si intende realizzare
- Lettera Direttore Generale INFM di disponibilita' a cofinanziamento
- Lettera Ditta PROMETE interessata all'ingegnerizzazione del prototipo.
- Lettera Ditta TLC di stanziamento finanziamento per commercializzazione dispositivo.



ISTITUTO NAZIONALE DI FISICA NUCLEARE

LABORATORI NAZIONALI DI LEGNARO

LEGNARO (PADOVA) 4 Luglio, 00

DIVISIONE ACCELERATORI

3536 11-7-00 tel. 61 209

Dott. G. Fortuna

Direttore

SEDI

Caro Direttore,

Con la presente ti trasmetto copia della lettera di intenti di conferimento borse di studi da parte della ditta TLC, interessata alla commercializzazione degli eventuali dispositivi che in collaborazione con l'INFN si intende studiare nell'ambito dell'isp. di gruppo V BENHUR

Cordialita'

Dott. V. Palmieri



Prof. Carlo Calandra
Presidente INFM
Corso Perrone 24 16100 Genova

p.c.
Prof. R. Vaglio
Unita' INFM
Universita' di Napoli "Federico II"
Piazzale Tecchio 80 80125 Napoli

e p.c. Dott. V. Palmieri
Laboratori Nazionali di Legnaro dell' INFN
Via Romea 4, 35020 Legnaro (PD)

Egregio Professore,

La TLC e' una ditta italiana da anni presente sul mercato internazionale di film sottili, impianti da sputtering e trattamento superficiale di materiali.

Punto di forza della nostra azienda e' il continuo impegno del nostro personale nel cercare di seguire in modo attivo l'evoluzione delle tecnologie connesse al nostro campo di interesse.

Pertanto e' nostro interesse cercare collaborazioni con quanti possono coadiuvarci a commercializzare ogni novita' nel settore in grado di orientare le tendenze di mercato.

Da contatti preliminari con il Dott. Palmieri dei Laboratori Nazionali di Legnaro dell' INFN, abbiamo realizzato che la combinazione dell' esperienza dell' Unita' INFM di Napoli sulla Magnetometria a flux gate con l'esperienza dei LNL - INFN di trattamento di cavitaa' superconduttrici ha portato al concepimento di un nuovo strumento per effettuare diagnostica locale del processo di etching chimico di cavitaa' localizzando i sensori localmente all' esterno della stessa. A nostra conoscenza questo strumento non esiste ancora sul mercato e pur, se in una fetta di utenza ristretta, potrebbe essere commercializzato in futuro.

E' nostra opinione che un'eventuale punto d'incontro fra i Vs. istituti di ricerca e la ns. azienda puo' essere favorito dal ns. incoraggiamento alla prosecuzione delle ricerche in tal senso. Pertanto nell' interesse di vagliare una possibile collaborazione futura con i Vs. gruppi, chiediamo la possibilitaa' di erogare un

Centro Direzionale Colleoni - V. Paracelso, 26 - Palazzo Cassiopea, 3 - 20041 Agrate Bza (MI) - Italy

Tel. ++39.039.689.0447 - Fax. ++39.039.688.1950 - E.mail. babroggi@tin.it

P.IVA & C.F. 02780050965 - N° Iscr. C.C.I.A.A. 189384/1998

contributo al netto di lit. 75 Milioni a favore dell' INFM da destinare alla costituzione di assegni di studio e ricerca o contratti di collaborazione da destinare ai gruppi operanti nel settore, allo scopo di consentirvi di proseguire con tranquillita' il vs. lavoro di ricerca nel campo e di costituire possibile titolo di precedenza nella selezione della ns. ditta per un' eventuale commercializzazione futura del dispositivo.

In attesa di Vs. gentile riscontro porgiamo distinti saluti.

Dr. Francesco Terenziani
TLC Srl Equipment & Assets

A handwritten signature in blue ink, appearing to read 'F. Terenziani', is written over a horizontal line. The signature is fluid and cursive, extending to the right of the line.

FLUX-GATE MAGNETOMETRY: THE POSSIBILITY TO APPLY A NOVEL TOOL TO MONITOR NIOBIUM CHEMISTRY

V. Palmieri, F. Stivanello, ISTITUTO NAZIONALE di FISICA NUCLEARE, Legnaro National Laboratories, Legnaro (PD), ITALY

M. Valentino ISTITUTO NAZIONALE di FISICA della MATERIA and Naples University "Federico II", Naples, ITALY

Abstract

Flux gate magnetometry is proposed as a possible diagnostics of the buffered chemical polishing of a resonator and for monitoring the hydrogen desorption from an hydrogenated niobium sample. The technique is contactless, non intrusive and enable the measurements of magnetic field in the range of pico-Tesla.

1. Introduction

The Buffered Chemical Polishing (BCP) is a standard procedure applied in several laboratories in order to etch bulk Niobium resonators [1]. For a long time a mixture of equal parts in volume of Hydrofluoric, Nitric and Phosphoric acid (the so-called BCP 1:1:1) has been adopted. More recently, the community has chosen to use a bath containing 2 parts of Phosphoric acid (BCP 1:1:2), that, due to the lower etching rate, has a more controllable and thermally stable chemical reaction. Even if of crucial importance, the chemical polishing is only one of the many steps of the resonator fabrication process. Hence, although the process parameters are carefully monitored, frequently BCP is just applied as a cookery recipe, and not as a result of searching the best process parameters. In addition to that, the Niobium chemistry is a topic only marginally covered by literature so far, and no clear answer is given to questions like: "How deep is the layer charged by hydrogen during the reaction?", "How important is the speed of the acid flowed into the resonator?", "In which way the contamination of the surface and the shape of the cavity affect the reaction?", "Is phosphoric acid playing merely the role of a reaction moderator?". Even the less fundamental question about the etching uniformity along the cavity profile has not an obvious solution, unless the cavity is cut in two halves or samples are inserted into a dummy resonator.

After the BCP it is common to bake the resonator at 800 °C in UHV, in order to favour the desorption of the hydrogen soluted during the Niobium chemical etching. For other reasons also, the baking of the resonator into the cryostat for 40 hours at 115 °C enables to achieve high performance resonators. All these procedures have

been found in an empirical way, and much more work has to be done in order to improve them. On the other side it is unpractical to measure several cavities only in order to understand if 50 hours of baking are better than 40 hours, or if the temperature of 115 °C is more effective then the one of 95 °C.

The Flux-Gate Magnetometer (FGM) is a solid state device able to measure magnetic fields in pico-Tesla range. It is frequently adopted in several applications, such as magnetic airborne detection, search and surveillance operations, non-destructive testing of materials, palaeomagnetism and exploration of magnetic field in space missions to outer planets [2].

We propose, herein, the detection of the magnetic field induced by the motion of the ions involved in the above-mentioned chemical reaction by this non-intrusive and contact less method. This is a novel application which allows to detect the dynamics of the reaction from the area outside the resonator and, whenever the external noise is screened, it is very sensitive to process parameters.

Concerning the Hydrogen solved into Niobium, due to the peculiar electronic configuration of Niobium $[\text{Kr}]4d^4 5s$, the spin interaction between Hydrogen and niobium is particularly strong, resulting into a well-known change of the metal paramagnetism during hydration.

A fluxgate magnetometry is a kind of diagnostics that can be used outside of a resonator, during the chemical etching in the same way in which the thermometry is used for the RF tests. In the authors opinion, this can be a suitable technique to join quantitative estimations to the thumb rules for the chemical polishing still adopted when getting rid of hydrogen from Niobium.

2. Niobium Chemistry

Niobium behaves as a corrosion hard metal: it is not alterable by water or hydrogen peroxide; it is not attacked by *HCl*, cold *H₂SO₄*, and *HNO₃* and their mixtures; *aqua-regia* has no effect [3].

According to Fig. 1, the Niobium is not in itself corrosion resistant and its immunity is due entirely to surface oxide

films. Two are the main ways to etch Niobium: a) in hot *NaOH* saturated solution and *Hydrogen Peroxide*; b) in *HF*, just adding some *HNO₃*.

In the former solution, the *Niobium pentaoxyde* is converted in *NaNbO₃*. The *Hydrogen Peroxide* oxidizes the *Sodium Niobate* into a *Perniobate Na₃NbO₈* that is unstable and gets easily hydrated. The main drawback of that attack is the Niobium embrittlement due to the formation of a hydrogen poor β -niobium hydrate with the formula *NbH_{0,7}*.

The latter process is definitely more convenient. Hydrofluoric acid alone has little effect on Niobium, but if some Nitric is added an exothermic reaction is immediately ignited. A little amount of Nitric acid indeed oxidizes Niobium; the hydrofluoric acid reduces the oxide into a halide salt that is soluble in water. Phosphoric acid is added in order to moderate the reaction.

Even if the reaction is more complex than this, the following formulas give a good description of the main mechanism:

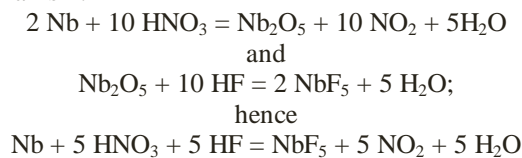

Among the several possible Niobium Oxides as *NbO*, *Nb₂O* and sub-oxides *NbO_x*, only the *Nb₂O₅* is stable and it is formed in the γ -phase in the aqueous solution by the nitric acid.

In reality several complex salts form during the reaction. The *NbF₅* has a tetrameric structure of the type *Nb₄F₂₀* composed of a square of Niobium atoms with interposed fluorine atoms in each half side, while the other fluorine atoms complete an octahedral around Niobium atoms. Fluorine-complexes, based on the *[NbF₆]* and on the less probable *[NbF₇]²⁻* anion, can be found in solution together with the complex oxo-halides *[NbOF₅]²⁻* and *[NbOF₆]²⁻*.

The Niobium does not form simple ionic phosphates, and the *NbOPO₄* is formed by the γ *Nb₂O₅* and Phosphoric acid.

The effect on the etching rate of the different percentage of the three acids is displayed in the ternary diagram of fig. 1 or equivalently in the 3-d graph of fig. 2. We can notice that the same etching rate of the 1:1:1 mixture can be obtained by decreasing the nitric percentage and increasing the phosphoric or vice versa. In other words, the reduction effect of Hydrofluoric acid is so high that a little fraction of the oxidant agent (nitric) is needed in order to solute Niobium; more Phosphoric in this case is needed for smoothing the reaction.

One could think that it is rather improbable that the lowest surface roughness and the lowest hydrogen absorption are obtained at the ratios 1:1:1 or 1:1:2 commonly utilised for Niobium cavities. The authors have explored the effect on roughness of different ratios for the *HF : HNO₃ : H₃PO₄* mixture. Measurements show that the etched Niobium roughness is more influenced by the quantity of phosphoric acid percentage rather than that of nitric acid.

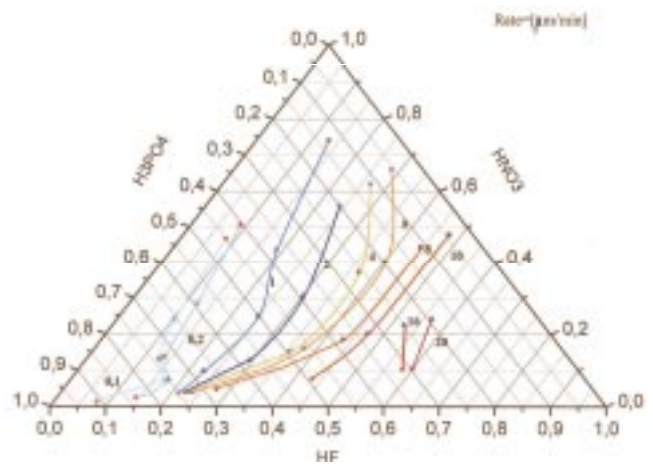

Fig. 1 Curves of equal etching rate (removed micron per minute) versus BCP percentages. We have etched Niobium cubes of 4 mm side into 40 ml of etching solution for 18 minutes.

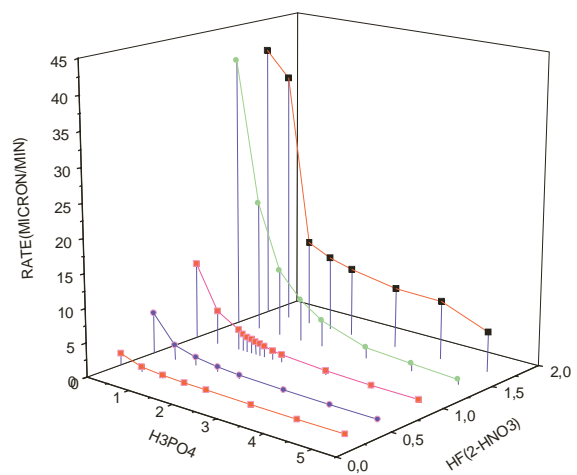

Fig. 2 The same data of Fig. 1 are here displayed in 3-d, by plotting the etching rate versus the phosphoric acid and hydrofluoric acid percentage (the nitric percentage is the complement to 1 of the hydrofluoric).

In order to assess the role of the three acids, we have elaborated the data for constructing the diagram of fig. 1. Let us call **f**, **n** and **ph** respectively the percentage of hydrofluoric, nitric and phosphoric acid in the general BCP mixture; we will also call **r** the etching rate, while we will define as the reaction moderation the quantity **m** = 1 / **r**. The etching rate of the solution **2 f** : **2 n** : **2 ph** is identical to that of the solution **f** : **n** : **ph**. Hence assuming the condition **f** + **n** = 2, we will restricted ourselves to observe only the effect of the two variables **n** and **ph**.

We will make the hypothesis that the rate or equivalently the moderation depend on **n** or **ph** as the product of two functions *a(n)* and *b(ph)*. This is equivalent to say that **n** and **ph** are two independent variables.

$$m(\mathbf{n}, \mathbf{ph}) = 1 / r = a(\mathbf{n}) \cdot b(\mathbf{ph})$$

In other words the only effect of nitric acid is only that of oxyding Niobium oxidant, while the effect of phosphoric acid is purely that of a reaction moderator; the nitric acid has no spurious effects as for instance dissociating the phosphoric.

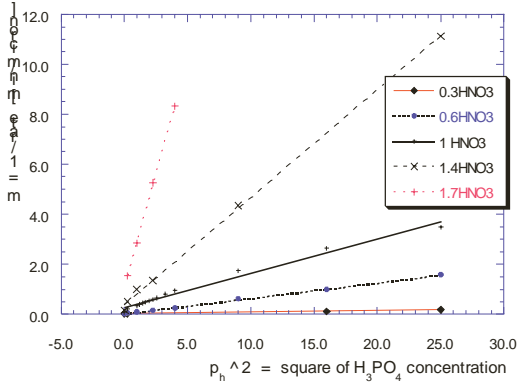

Fig. 3 The inverse of the etching rate is a linear function of the square of the phosphoric acid concentration.

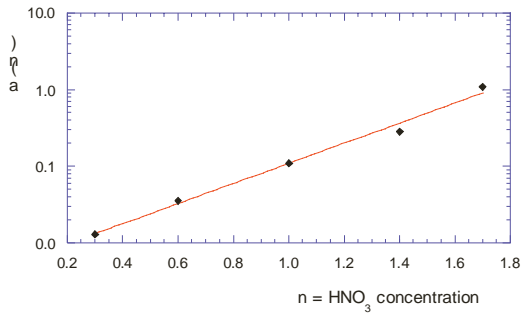

Fig. 4. The moderation effect is exponentially dependent on $3n$.

In the range of n from 0.3 to 1.7, experimental data show that the best fit of $b(\mathbf{ph})$ is a parabola, while that of $a(\mathbf{n})$ is an exponential function.

Our best fit is the following,

$$m(n, \mathbf{ph}) = 5 \cdot 10^{-3} \cdot e^{(3n)} \cdot (1 + 1.7 \mathbf{ph}^2)$$

The absence of the linear term in \mathbf{ph} makes supposing that the experimental dependence found for the function $b(\mathbf{ph})$ are the first terms of a Taylor series of an even function, as a hyperbolic cosine for instance. The exponential behaviour can be interpreted in the following way: The oxidation of the niobium is compulsory for the formation of the Halide salt. However as far as a certain threshold is reached, the niobium oxide works as a kind of passivated layer for the hydrofluoric acid.

3. The Fluxgate Magnetometer

The working principle of a FGM is based on the non-linearity of the magnetic characteristic of ferromagnetic core material in its sensing element. The device measures the d.c. or the low-frequency a.c. component of the

magnetic field parallel to the axis of the sensing element, with a sensitivity which ranges from 10^{-11} up to 10^{-4} Tesla. In its simplest configuration, the sensor consists of a cylindrical core of high permeability material around which two coaxial coils have been wound. One coil may be called the "bias coil", while the other the "sensing coil", as shown in the basic configuration of Fig.5.

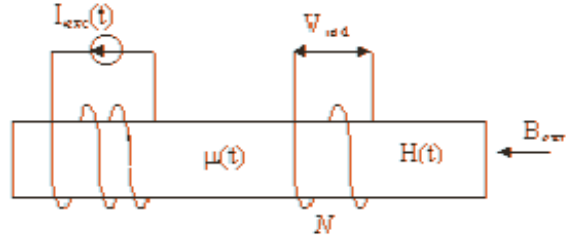

Fig.5. Bare sensor configuration. The sensor core is excited by an a.c. current I_{exc} in the excitation winding so that the core permeability $\mu(t)$ is modulated. B_{ext} is the measured magnetic field and $H(t)$ the corresponding field in the sensor core. The voltage output in the pick-up coil with N turns is V_{ind} .

The fluxgate provides a voltage difference proportional to the applied field, the basic analytical description may start from the Faraday law:

$$V_{ind} = d\Phi/dt = d(NA\mu_0\mu(t)H(t))/dt$$

where $\Phi=BA$ is the magnetic flux in the material; A is the area of the sensor perpendicular to the magnetic field; $H(t)$ is the magnetic field in the sensor core and $\mu(t)$ is the sensor core relative permeability. The permeability of the core is usually modulated by superimposing an a.c. magnetic field which causes the permeability to go trough a maximum twice per drive cycle. This produces a voltage proportional to B_{ext} at the second harmonic of the drive frequency. In the design of a real sensor the magnetic field H , due to demagnetisation effects, is lower than the measured field H_{exc} outside of the sensor core. For this reason the output equation of the induced voltage becomes:

$$V_{ind} = NAdB/dt = NA\mu_0H_{exc}(1-D)/[1+D(\mu-1)]^2 d\mu(t)/dt$$

being D the effective demagnetising factor.

The magnetic signal is detected generally by using a Phase Sensitive Detection technique (PSD), further details about the electronics characteristics of such magnetometers are in reference [4]. The PSD technique used for the sensor enables it to work in a bandwidth ranging from d.c. to a few kHz, typically 3-5 kHz.

The noise limiting the sensitivity of a fluxgate is determinate by the Barkhausen noise associated with movement of domain walls in the core as bias is applied [5]. The resolution of the fluxgate magnetometer is principally limited by the stability of the zero sensor. The change of the offset depends by the noise level and on the time instability of the sensor [6]. The spectral density of

the magnetic field noise is roughly constant from frequencies below about 1Hz up to 1kHz. In high quality commercial systems the corresponding noise level can be as low 20pT/Hz^{1/2} in a magnetically shielded chamber.

4. Experiment and results

The following measurements have been performed:

- 1) Monitoring of the magnetic signal due to the Niobium chemical etching of different BCP 1:1:x solution, ranging between 1:1:1 and 1:1:2, in order to detect any correlation of the magnetic signal versus the etching rate.
- 2) Monitoring of the magnetic signal above a Copper cavity (at the equator and at the cut-off tube close to the iris) across which a flow of Ammonium Persulphate was fluxed, in order to detect the different corrosion effect.
- 3) Magnetic field measurements in a gradiometric configuration above a electrolytically hydrogenated Niobium sample.

4.1 The flux gate signal for monitoring the etching rate for Nb pills in BCP 1:1:x

We have monitored the magnetic signal caused by the Niobium chemical etching of different BCP 1:1:x solution, investigating the region between 1:1:1 and 1:1:2, in order to detect any correlation with the etching rate.

4.1.1 Experimental set-up

The magnetic signal due to the ongoing etching on Niobium high purity material in acid solution, has been detected using a low noise commercial fluxgate magnetometers (Bartington). In order to reduce the environmental magnetic noise, the sensors have been mounted in gradiometric configuration inside a magnetic shield consisted of three coaxial cylinders of mu-metal and aluminium. The 6 mm thick outer aluminium shield has a length of 250 mm and an internal diameter of 90mm. The 0.1mm thick mu-metal cylinder in the middle has a length of 245mm and a diameter of 70mm. The inner 1.5mm thick aluminium shield is 240mm high and has a diameter of 65mm. The overall structure is designed to avoid mechanical vibration during the experiments.

The 3mm thick Niobium disk with a diameter of 35mm is located inside a Teflon vessel, contained the acid solution, and it is mounted on the detector magnetometer, the overall distance between the metallic disk and the sensor is 1.1mm. The sensors are orientated in order to detect the component of magnetic field parallel to the niobium disk surface. The geometrical details of the experimental set-up are sketched in Fig.6.

In order to decrease the intensity of the static earth magnetic field and to reject noise disturbances from distant field source, the output voltage of the two magnetometers located at different distances from the sample are electronically subtracted. In this way the spatial first derivative of the magnetic field is measured. In this type of configuration, called electronic gradiometer, it is essential to optimise the distance

between the sensors, defined baseline, to remove magnetic noise disturbances without subtracting significant amount of signal [7]. The optimised baseline used in this work is 80 mm.

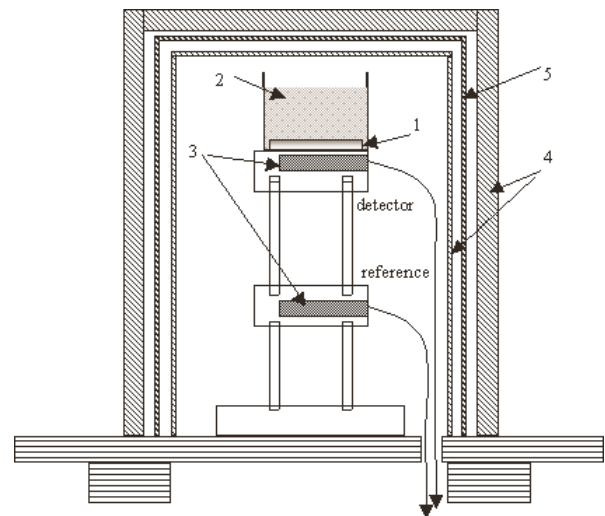

Fig 6. Experimental set-up. 1) Niobium disk; 2) Teflon vessel filled with 40ml of Acid solution; 3) Fluxgate magnetometers sensors housed in a Plexiglas holder: detector and reference magnetometers are in a first order gradiometer configuration; 4) Aluminium shields; 5) mu-metal shield.

Successively the signal is filtered and amplified in the bandwidth ranging from 0.0 to 3.0Hz using an EG&G 110 PARC amplifier. Finally the signal is time and frequency domain analysed using a HP 35670A-spectrum analyser.

4.1.2 Results

For the chemical etching on Niobium disks, the measurements have been done in the frequency domain in the bandwidth 0-1.5Hz. The fluxgate conversion factor was 143000 V/T. Sensors were filtered in the bandwidth 0-3Hz by a battery supplied Par Amplifier. The baseline of the measurement gradiometer was 80 mm.

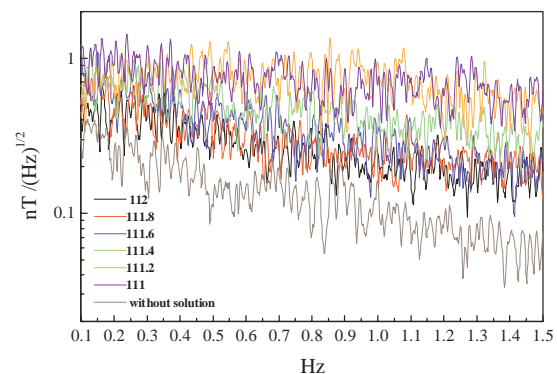

Fig. 7 Spectrum of the magnetic signal versus frequencies. Passing from BCP 1:1:2 to BCP 1:1:1, decreasing the phosphoric percentage, the signal becomes monotonically more and more intense.

The screening due to the mu-metal and the double aluminium screen at frequency line power (50 Hz) was of 54 dB in a further Faraday cage. In this conditions, the gradiometer sensitivity, measured at frequency of 1Hz was of 11pT. The total time of acquisition was of 18 minutes and the average charging time 14 sec.

The measured spectra of fig. 7 clearly show a dependence of the magnetic signal from the phosphoric acid concentration in the bandwidth 0.015- 1.5Hz.

The behaviour of magnetic field versus the percentage x of the phosphoric acid in BCP is plotted in figure 8, by reporting the integral average of the acquired spectra.

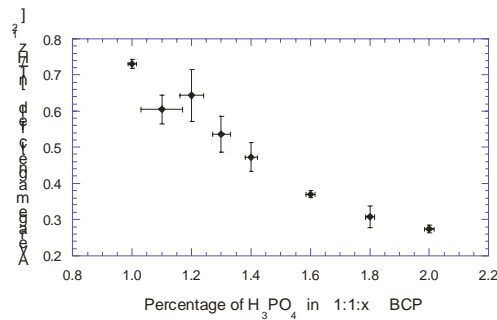

Fig. 8 Average of magnetic field calculated integrating the spectra in figure 7.

In figure 9 the average field is plotted versus the etching rate. The possibility to plot data along a straight line gives the best indication of the device linearity for this application.

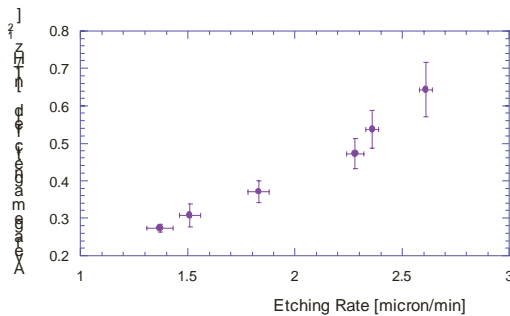

Fig.9 The average field is plotted versus rate. The measurements for $x = 1$ and $x = 1.2$ were not considered due to the uncontrollable heating of the solution.

4.2 Flux gate monitoring externally to a 3 GHz Copper resonator during the etching

We have monitored of the magnetic signal above a Copper cavity (at the equator and at the cut-off tube close to the iris) across which a flow of Ammonium Persulphate was fluxed, in order to detect the different corrosion effect.

4.2.1 Experimental set up

Two sensors have been set in magnetometer configuration outside a 3 GHz Copper mono-cell resonator. The sensor $B2$ was located at the equator,

while the sensor $B1$ was located on the cut-off tube close to the iris, both the sensors are oriented to measure the magnetic field parallel to the Copper surface.

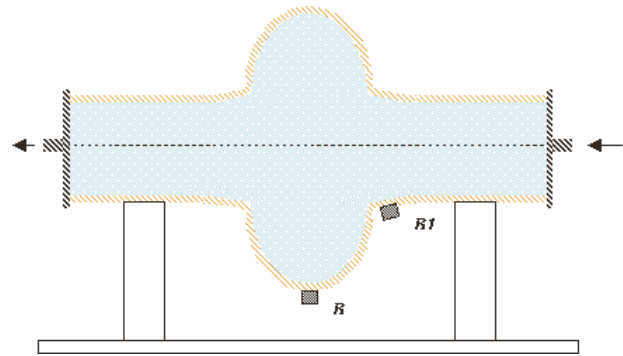

Fig. 10 The cavity is a 3GHz Copper monocell placed horizontal into a double mu-metal tubular screen alternated by three Aluminium tubes. The flux of Ammonium Persulphate in a concentration of 30 g/l is of the order of 1lt/min. The measurement takes around 45 minutes and the rms values of the magnetic field are obtained up 500 averages. The probes $B1$ and $B2$ are in a magnetometer configuration.

4.2.2 Results

Figure 11 reports the detected average field (in the Pico-Tesla range). The reported values have been extracted from the noise spectra integrating on the 0.03-1.556Hz bandwidth.

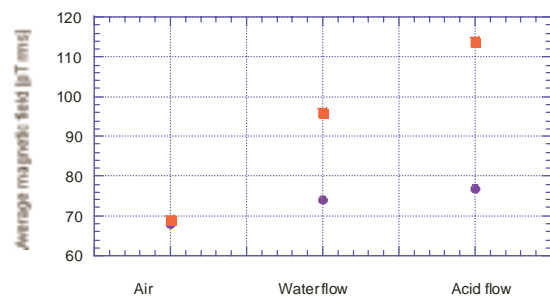

Fig. 11. Average magnetic field at the equator $B2$ (blue dots) and at the iris $B1$ (red squares). The measurements were done out of the cavity in three different conditions: a) the cavity was empty with no liquid flowing; b) into the cavity was circulating a deionized water flow; c) the cavity was chemically etched by circulating Ammonium peroxide solution

From the measurements, it appears the following: when no liquid circulates into the cavity, the magnetic field value at the iris and at the equator coincide; The signal difference becomes more evident already when the water is flowing, presumably due to the Copper Oxydation. The signal becomes definitely stronger as soon the acid is flowing into the cavity.

4.3 Measurements on a hydrogenated Niobium sample

We have performed magnetic field measurements in a gradiometric configuration above a electrolytically hydrogenated. Niobium sample. In order to desorb the hydrogen solved into Niobium after the first measurement the sample was baked in vacuum at a temperature of 100 °C, for 6 hours.

The reaction between Hydrogen and Niobium involves three main processes adsorption, absorption and diffusion. The most favourable temperature to which Niobium must be heated then for Hydrogen desorption is 900 °C. However partial desorption starts already at 100 °C [8].

As displayed in fig. 12 the difference between the measurement before and after vacuum baking of the Niobium sample shows a substantial difference between the two signals before and after baking, the maximum difference being about 230 pT.

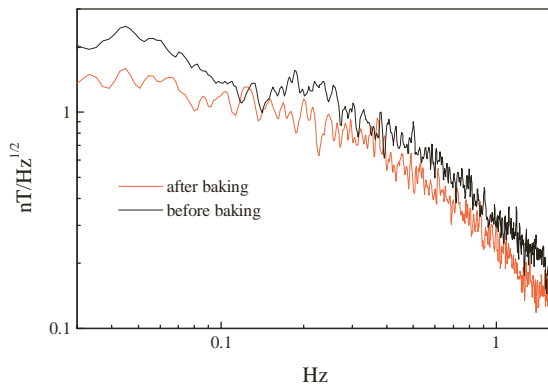

Figure 12 Spectra taken in gradiometric configuration for an hydrogenated niobium sample before and after five hours of vacuum baking and further nine hours of pumping.

5. Conclusions

In this paper we have considered the application of the fluxgate magnetometry as powerful diagnostics technique in the field of superconducting cavities for particle accelerators. In particular the preliminary results we presented herein confirm the possibility to investigate in a contactless and non intrusive way the ongoing corrosion of cavities due to the chemical polishing. The authors suggest also the use of FGM for monitoring the hydrogen desorption from Niobium heated under vacuum. A more detailed investigation on a real cavity is needed. To detect very small hydrogen quantities, FGM

sensitivity can be further enhanced by substitution of the sensor material or by changing geometry, electronic detection and noise rejection techniques. Nevertheless, when the sensitivity of FGM to the amount of hydrogen segregation turns to be too poor, this limitation may be overcome by adopting a more sensitive magnetic field detectors as the SQUIDs (Superconducting Quantum Interference Devices), that, in the same shielded conditions, reach sensitivity as low as 0.07 pT/Hz^{1/2} at 1 Hz.

Acknowledgements

The authors are indebted to Prof. A. Barone for having ignited our collaboration, to M. Lollo, A. Maggio, S. Marrazzo, R. Preciso, and F. Poletto, W. Venturini, for assistance in the set up of the experimental apparatus.

References

- [1] P. Kneisel, "A selection of higher gradient cavity experiments", Proceedings of the Eighth workshop on RF Superconductivity, Abano Terme, 1997, V. Palmieri, A. Lombardi eds., LNL-INFN (Rep) 133/98, p. 830.
- [2] D.I Gordon and R.e. Brown "Recent advances in Fluxgate Magnetometry" IEEE Trans. Magn., **8**, 70-83 (1972), see also P. Ripka "Review of fluxgate sensors" Sensors and Actuators A **33**, 129-141 (1992)
- [3] J. Van Muylder, M. Pourbaix, " Electrochemical Behaviour of Niobium", Tech Rep. No. 53 (1957), Centre Belge d'etude de la corrosion, Brussels, 444, 441.
- [2] F Primdahl , B Hernando, O. V. Nielsen and J.R. Petersen "Demagnetising factor and noise in the fluxgate ring-core sensor" J. Phys. E: Sci. Instrum **22**, 1004-1008 (1989)
- [5] J. Deak et al." A low noise fluxgate single domain" App. Phys. Lett. **8**, 1157-1159 (1996)
- [6] D.C. Scouten "Noise in low level fluxgate magnetometers" IEEE Trans. Magn MAG-**8**, 223-231 (1972)
- [7] M. Valentino, A. Ruosi, G. Pepe, G. Peluso "Comparison between traditional and SQUID magnetometry in eddy-current NDE" Edt. D. Lesselier Studies in Applied Electromagnetic and Mechanics, IOS Press, 159- 170 (1999).
- [8] W. Albrecht, M. Mallet, W. Goode, "Equilibria in Niobium hydrogen system, J. Elchem. Soc., 105 1958 219, p. 461.

Esperimento

gruppo

Rappresentante nazionale

Struttura res. naz

nuovo continua

BENHUR

5

V. PALMIERI

LNL

nuovo

STR.	ESPERIM.	Missioni interno	Inviti ospiti stran.	Missioni estero	Mater. di Cons.	Spes Sem	Tras. e Fac.	Pub. Scien.	Spese Calc	Aff. e Manut. App.	Mater. invent.	Costruz. apparati	TOTALE
L.N.L.	Personale												
	Ricercatori		2,0	Tecnologi			Tecnici			2,0	Servizi mesi uomo		
	FTE		0,4	FTE			FTE			0,5	3,0		
	Rapporti (FTE/numero) Ricercatori				0,20				Ricercatori+Tecnologi				0,20
	BENHUR	9		15	20							80	124
	di cui sj												
	Totali	9		15	20							80	124
	di cui sj												
	Richieste/(FTE ricercatori+tecnologi)				310,00								
	TOTALI												
Totali	9		15	20								80	124
di cui sj													
Confronto con il modello EC4													
Mod. EC4 dati													
Totali-Dati EC4	9,0		15,0	20,0								80,0	124,0
Personale													
Ricercatori		2,0	Tecnologi			Tecnici			2,0	Servizi mesi uomo			
FTE		0,4	FTE			FTE			0,5	3,0			
Rapporti (FTE/numero) Ricercatori				0,20				Ricercatori+Tecnologi				0,20	
Richieste/(FTE ricercatori+tecnologi)				310,00									